

PMK Series

SMALL FLANGE MOUNTED TYPE

PMK TYPE

- ▶ Output range : 3phase 0.2~3.7kW
- ▶ Rated reduction gear ratio : 1/5~1/200
- ▶ Installation type : Vertical



Product Coding

SERIES	MOUNTING	FRAME NO	RATIO	EFFICIENCY	TYPE	OUTPUT	VOLTAGE	LOCATION
PM	K	<input type="checkbox"/>	<input type="checkbox"/>	<input type="checkbox"/>	<input type="checkbox"/>	<input type="checkbox"/>	<input type="checkbox"/>	<input type="checkbox"/>



PMK Series 3-Phase

0.2kW

■ SPECIFICATION

■ MOTOR

Output (kW)	Model Name	Poles	Voltage (V)	Freq. (Hz)	Rated Load			Duty	Degrees of protection	Insulation Classification	Protective Cooling System
					Current (A)	Speed (r/min)	Efficiency (%)				
0.2	PMK□-□-□M□020R4□	4	220/380	60	1,10/0,60	1715	71,5	CONT.	IP55 (IP40)	F	Totally Enclosed Fan-Cooled
	PMK□-□-□M□020W6□	4	200	50	1,10	1415	71,7				
			200/220	60	1,00/1,00	1690/1715	72,8/73,2				
	PMK□-□-□M□020X6□	4	380/400	50	0,60/0,60	1410/1420	71,0/67,2				
			400/440	60	0,50/0,50	1700/1720	70,8/73,4				

Note) • The Brake Geared Motor is divided into 2 models : one is a non-water proof product with IP40 while the other is a waterproof product with IP55.

• The Models with IP40 and IP55 have the same electric characteristics.

■ GEARED MOTOR – 50Hz

Frame No.	88																
Reduction gear ratio	5	10	15	20	30	40	50	60	75	★90	★100	★120	★140	★150	★160	★180	★200
Rotation speed (r/min)	300	150	100	75	50	37,5	30	25	20	16,6	15	12,5	10,7	10	9,3	8,3	7,5
Allowable torque	kgf · m	0,62	1,2	1,9	2,5	3,7	4,8	6	7,2	9	9,9	9,9	9,9	9,9	9,9	9,9	9,9
	N · m	6,1	11,8	18,6	24,5	36,3	47	58,8	70,6	88,2	97	97	97	97	97	97	97
Allowable O.H.L	kgf	90	120	140	150	180	190	200	220	240	250	250	250	250	250	250	250
	N	882	1180	1370	1470	1760	1860	1960	2160	2352	2450	2450	2450	2450	2450	2450	2450

Frame No.	105								
Reduction gear ratio	90	100	120	140	150	160	180	200	
Rotation speed (r/min)	16,6	15	12,5	10,7	10	9,3	8,3	7,5	
Allowable torque	kgf · m	10,7	11,9	14,3	16,7	17,9	19,1	21,4	23,9
	N · m	105	117	140	164	175	187	210	234
Allowable O.H.L	kgf	260	290	340	350	350	350	350	
	N	2548	2840	3330	3430	3430	3430	3430	

■ GEARED MOTOR – 60Hz

Frame No.	88																
Reduction gear ratio	5	10	15	20	30	40	50	60	75	★90	★100	★120	★140	★150	★160	★180	★200
Rotation speed (r/min)	360	180	120	90	60	45	36	30	24	20	18	15	12,8	12	11,2	10	9
Allowable torque	kgf · m	0,51	1	1,5	2,1	3,1	4	5	6	7,5	8,2	8,2	8,2	8,2	8,2	8,2	8,2
	N · m	5	9,8	14,7	20,6	30,4	39,2	49	58,8	67,5	80,4	80,4	80,4	80,4	80,4	80,4	80,4
Allowable O.H.L	kgf	90	120	140	150	180	190	200	220	240	250	250	250	250	250	250	250
	N	882	1180	1370	1470	1760	1860	1960	2160	2352	2450	2450	2450	2450	2450	2450	2450

Frame No.	105								
Reduction gear ratio	90	100	120	140	150	160	180	200	
Rotation speed (r/min)	20	18	15	12,8	12	11,2	10	9	
Allowable torque	kgf · m	9	10	11,9	13,9	14,9	15,9	17,9	19,9
	N · m	88	98	117	136	146	156	175	195
Allowable O.H.L	kgf	260	290	340	350	350	350	350	
	N	2548	2840	3330	3430	3430	3430	3430	

Note) • Permissible O.H.L (allowable overhung load) is based on the central part of the outlet length for output shaft

• Permissible Torque is limited for the product with a mark "★" of reduction gear ratio

• Color indicates the same direction of motor rotation, while other color indicates the opposite direction of motor rotation.

PMK TYPE DIMENSIONS [Lead wire Box Type]

UNIT = mm

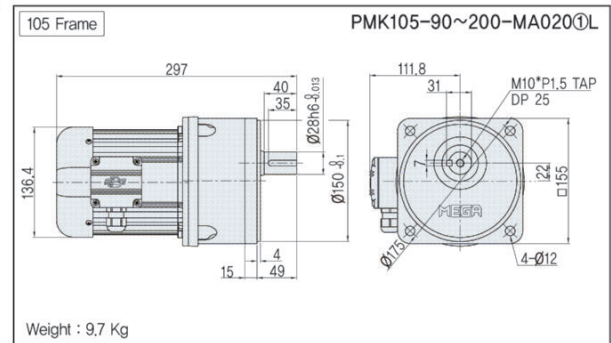
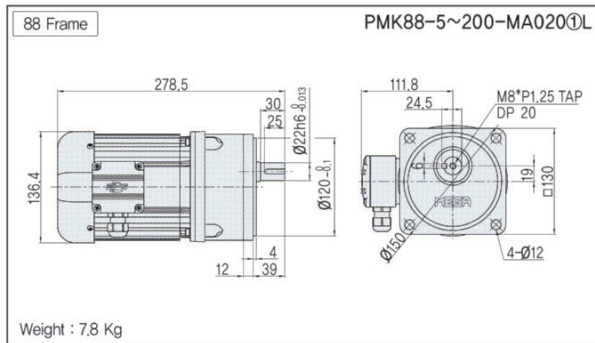

• Model type

① : Power (Voltage & Frequency)

PMK TYPE DIMENSIONS [Terminal Box Type]

Note) • Dimensions for IP40 model and IP55 model are the same.

• The brake-attached model is applied to the Terminal Box Type for basic features, but does not apply to the lead box.

UNIT = mm

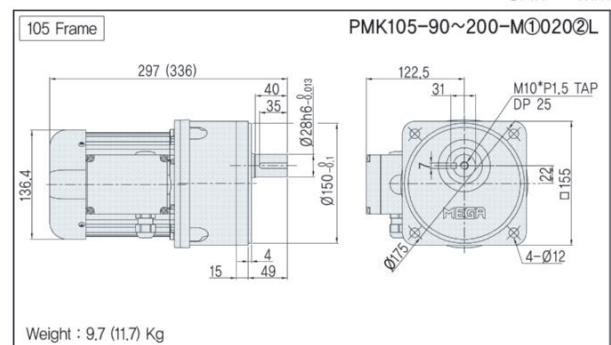
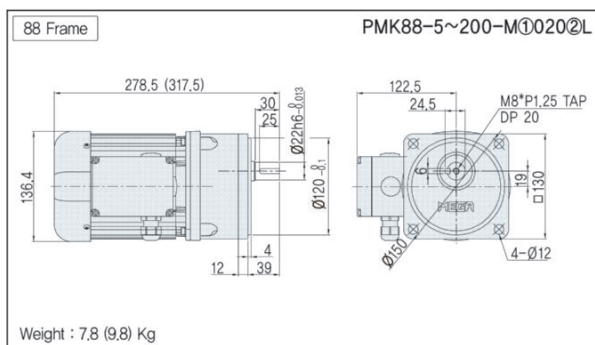

• Model type

① : Motor option (B, C, D)

② : Power (Voltage & Frequency)

※ Geared motors between 0.2~0.75kW, the size of the lead wire box and the terminal box is different.

Model Name Coding
5Page

Specification for output shaft
36Page

Technological Data
37Page~



PMK Series 3-Phase

0.4kW

■ SPECIFICATION

■ MOTOR

Output (kW)	Model Name	Poles	Voltage (V)	Freq. (Hz)	Rated Load			Duty	Degrees of protection	Insulation Classification	Protective Cooling System
					Current (A)	Speed (r/min)	Efficiency (%)				
0.4	PMK□-□-M□040R4□	4	220/380	60	2.00/1.20	1730	74.1	CONT.	IP55 (IP40)	F	Totally Enclosed Fan-Cooled
	PMK□-□-M□040W6□	4	200	50	2.20	1450	74.2				
			200/220	60	1.80/1.90	1735/1745	76.4/75.7				
	PMK□-□-M□040X6□	4	380/400	50	1.10/1.10	1425/1430	75.5/74.1				
400/440			60	1.00/1.00	1710/1725	75.4/75.2					

Note) • The Brake Geared Motor is divided into 2 models : one is a non-water proof product with IP40 while the other is a waterproof product with IP55.

• The Models with IP40 and IP55 have the same electric characteristics.

■ GEARED MOTOR – 50Hz

Frame No.	88					105											
Reduction gear ratio	5	10	15	20	30	5	10	15	20	30	40	50	60	75	★90	★100	
Rotation speed (r/min)	300	150	100	75	50	300	150	100	75	50	37.5	30	25	20	16.6	15	
Allowable torque	kgf · m	1.2	2.5	3.7	4.9	7.4	1.2	2.5	3.7	4.9	7.4	9.6	11.9	14.3	17.9	19.7	19.7
	N · m	12	25	36	48	73	12	25	36	48	73	94	117	140	175	193	193
Allowable O.H.L	kgf	90	120	140	150	180	130	180	220	240	260	290	320	350	350	350	350
	N	882	1180	1370	1470	1760	1270	1760	2160	2350	2550	2840	3140	3430	3430	3430	3430

Frame No.	135								
Reduction gear ratio	90	100	120	140	150	160	180	200	
Rotation speed (r/min)	16.6	15	12.5	10.7	10	9.3	8.3	7.5	
Allowable torque	kgf · m	21.5	23.9	28.7	33.5	35.9	38.2	43	44
	N · m	210	234	281	328	351	374	421	431
Allowable O.H.L	kgf	450	500	600	600	600	600	600	600
	N	4410	4900	5880	5880	5880	5880	5880	5880

■ GEARED MOTOR – 60Hz

Frame No.	88					105											
Reduction gear ratio	5	10	15	20	30	5	10	15	20	30	40	50	60	75	★90	★100	
Rotation speed (r/min)	360	180	120	90	60	360	180	120	90	60	45	36	30	24	20	18	
Allowable torque	kgf · m	1	2.1	3.1	4.1	6.2	1	2.1	3.1	4.1	6.2	8	10	11.9	15	16.4	16.4
	N · m	10	21	30	40	61	10	21	30	40	61	78	98	117	147	161	161
Allowable O.H.L	kgf	90	120	140	150	180	130	180	220	240	260	290	320	350	350	350	350
	N	882	1180	1370	1470	1760	1270	1760	2160	2350	2550	2840	3140	3430	3430	3430	3430

Frame No.	135								
Reduction gear ratio	90	100	120	140	150	160	180	200	
Rotation speed (r/min)	20	18	15	12.8	12	11.2	10	9	
Allowable torque	kgf · m	17.9	19.9	23.9	27.9	29.9	31.9	35.8	39.8
	N · m	176	195	234	273	293	313	351	390
Allowable O.H.L	kgf	450	500	600	600	600	600	600	600
	N	4410	4900	5880	5880	5880	5880	5880	5880

Note) • Permissible O.H.L (allowable overhung load) is based on the central part of the outlet length for output shaft

• Permissible Torque is limited for the product with a mark "★" of reduction gear ratio

• ■ Color indicates the same direction of motor rotation, while other color indicates the opposite direction of motor rotation.

PMK TYPE DIMENSIONS [Lead wire Box Type]

UNIT = mm

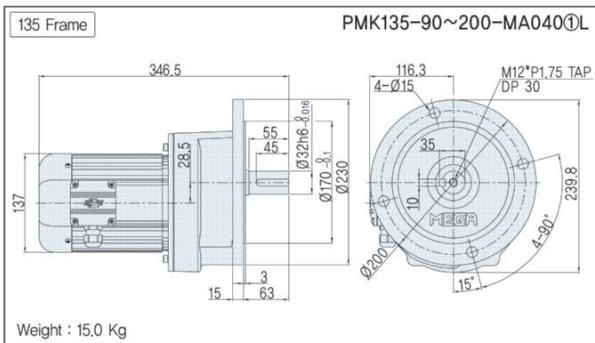
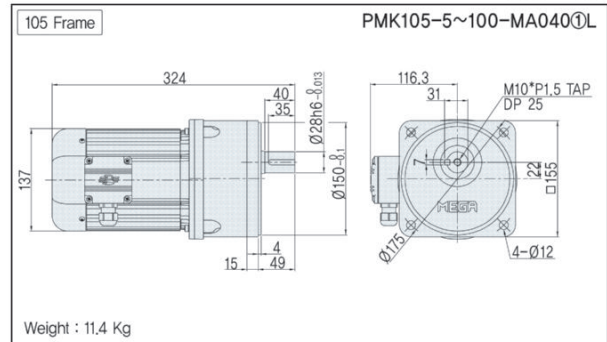
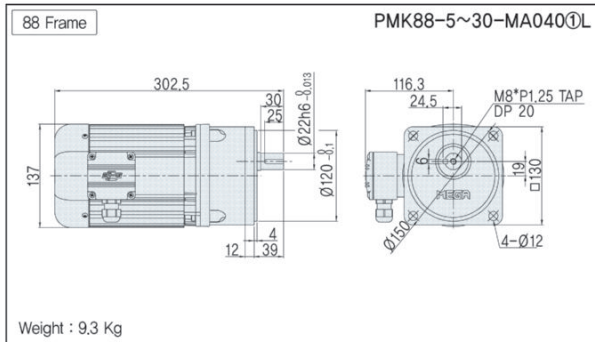

• Model type

① : Power (Voltage & Frequency)

PMK TYPE DIMENSIONS [Terminal Box Type]

Note) • Dimensions for IP40 model and IP55 model are the same.

• The brake-attached model is applied to the Terminal Box Type for basic features, but does not apply to the lead box.

UNIT = mm

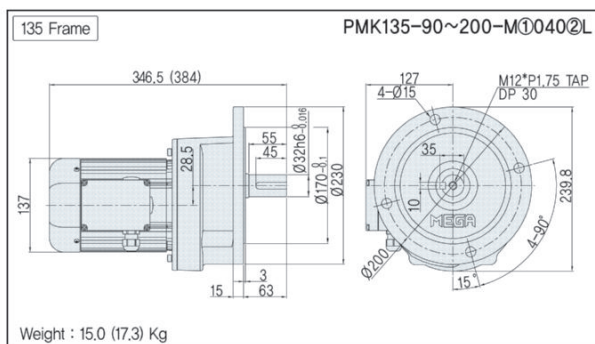
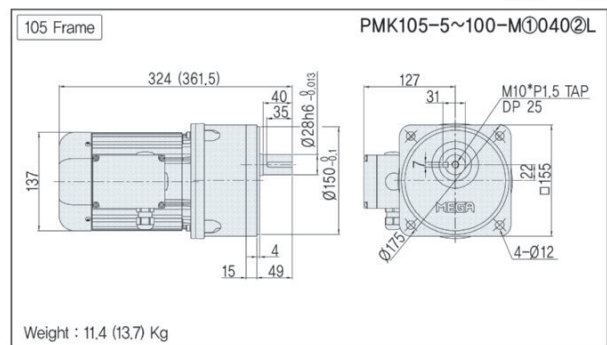
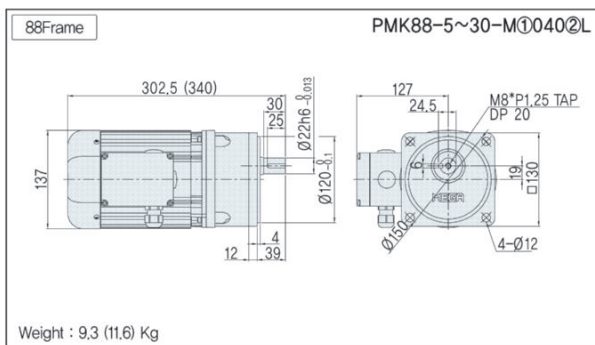

• Model type

① : Motor option (B, C, D)

② : Power (Voltage & Frequency)

※ Geared motors between 0.2~0.75kW, the size of the lead wire box and the terminal box is different.



High Efficiency

PMK Series 3-Phase

0.75kW

■ SPECIFICATION

■ MOTOR

Output (kW)	Model Name	Poles	Voltage (V)	Freq. (Hz)	Rated Load			Duty	Degrees of protection	Insulation Classification	Protective Cooling System
					Current (A)	Speed (r/min)	Efficiency (%)				
0.75	PMK□-□-E□075R4□	4	220/380	60	3,10/1,80	1705	82,8	CONT.	IP55 (IP40)	F	Totally Enclosed Fan-Cooled
	PMK□-□-E□075W6□	4	200	50	3,45	1415	79,6				
			220	60	3,10	1710	83,5				
	PMK□-□-E□075X6□	4	380/400	50	1,80/1,80	1420/1425	79,6/79,6				
400/440			60	1,65/1,60	1700/1720	82,5/82,9					

Note) • The Brake Geared Motor is divided into 2 models : one is a non-water proof product with IP40 while the other is a waterproof product with IP55.

• The Models with IP40 and IP55 have the same electric characteristics.

■ GEARED MOTOR – 50Hz

Frame No.	105					135											
Reduction gear ratio	5	10	15	20	30	5	10	15	20	30	40	50	60	75	★90	★100	
Rotation speed (r/min)	300	150	100	75	50	300	150	100	75	50	37,5	30	25	20	16,6	15	
Allowable torque	kgf · m	2,3	4,6	6,9	9,3	13,9	2,3	4,6	6,9	9,3	13,9	17,9	22,4	26,9	33,6	36,9	36,9
	N · m	23	45	68	91	114	23	45	68	91	114	175	220	264	329	362	362
Allowable O.H.L	kgf	130	180	220	240	260	180	250	290	330	410	430	470	560	600	600	600
	N	1270	1760	2160	2350	2550	1760	2450	2840	3230	4020	4210	4610	5490	5880	5880	5880

Frame No.	153												
Reduction gear ratio	40	50	60	75	90	100	120	140	150	160	180	★200	
Rotation speed (r/min)	37,5	30	25	20	16,6	15	12,5	10,7	10	9,3	8,3	7,5	
Allowable torque	kgf · m	17,9	22,4	26,9	33,6	40,3	44,8	53,8	62,7	67,2	71,7	78	78
	N · m	175	220	264	329	395	439	527	615	659	703	764	764
Allowable O.H.L	kgf	430	470	560	700	720	720	720	720	720	720	720	720
	N	4210	4610	5490	6860	7060	7060	7060	7060	7060	7060	7060	7060

■ GEARED MOTOR – 60Hz

Frame No.	105					135											
Reduction gear ratio	5	10	15	20	30	5	10	15	20	30	40	50	60	75	★90	★100	
Rotation speed (r/min)	360	180	120	90	60	360	180	120	90	60	45	36	30	24	20	18	
Allowable torque	kgf · m	1,9	3,9	5,8	7,7	11,6	1,9	3,9	5,8	7,7	11,6	14,9	18,7	22,4	28,1	30,8	30,8
	N · m	19	38	57	75	114	19	38	57	75	114	146	183	220	275	302	302
Allowable O.H.L	kgf	130	180	220	240	260	180	250	290	330	410	430	470	560	600	600	600
	N	1270	1760	2160	2350	2550	1760	2450	2840	3230	4020	4210	4610	5490	5880	5880	5880

Frame No.	153												
Reduction gear ratio	40	50	60	75	90	100	120	140	150	160	180	200	
Rotation speed (r/min)	45	36	30	24	20	18	15	12,8	12	11,2	10	9	
Allowable torque	kgf · m	14,9	18,7	22,4	28,1	33,7	37,3	44,8	52,2	56	59,7	67,1	74,7
	N · m	146	183	220	275	330	366	439	512	548	585	658	732
Allowable O.H.L	kgf	430	470	560	700	720	720	720	720	720	720	720	720
	N	4210	4610	5490	6860	7060	7060	7060	7060	7060	7060	7060	7060

Note) • Permissible O.H.L (allowable overhung load) is based on the central part of the outlet length for output shaft

• Permissible Torque is limited for the product with a mark "★" of reduction gear ratio

• Color indicates the same direction of motor rotation, while other color indicates the opposite direction of motor rotation.

Model Name Coding
▶ 5Page

Specification for output shaft
▶ 36Page

Technological Data
▶ 37Page~

PMK TYPE DIMENSIONS [Lead wire Box Type]

UNIT = mm

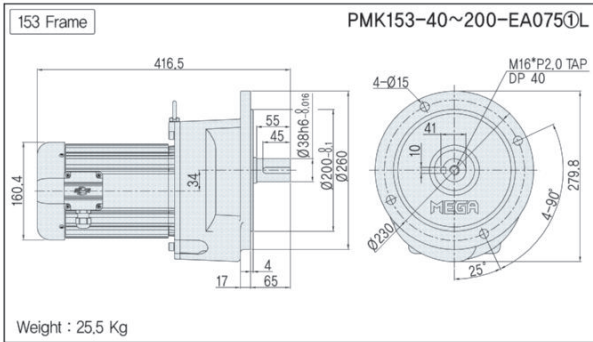
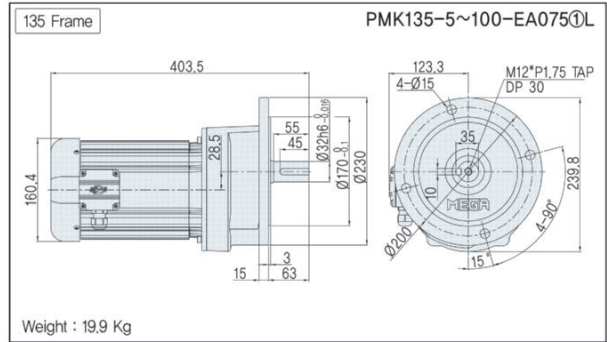
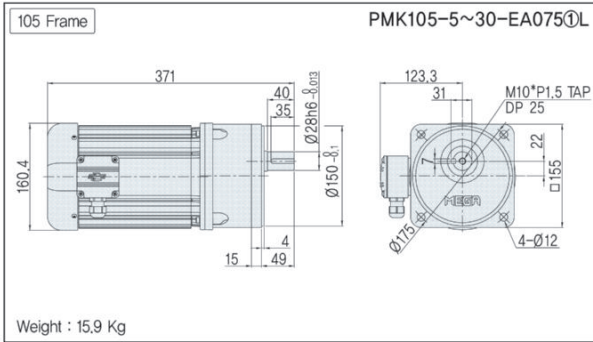

- Model type
- ① : Power (Voltage & Frequency)

PMK TYPE DIMENSIONS [Terminal Box Type]

- Note) • Dimensions for IP40 model and IP55 model are the same.
 • The brake-attached model is applied to the Terminal Box Type for basic features, but does not apply to the lead box.

UNIT = mm

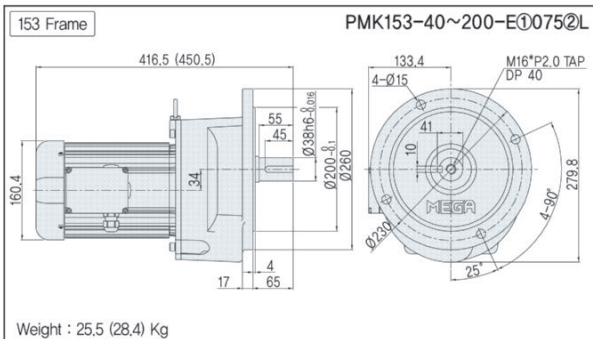
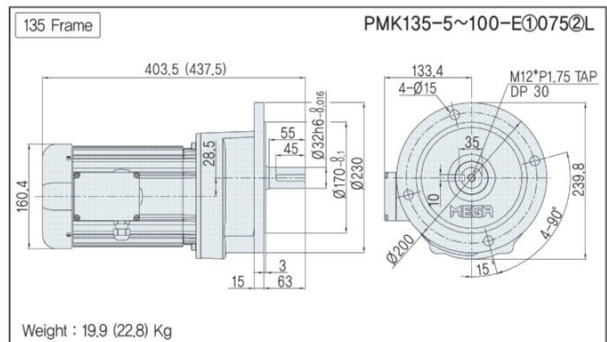
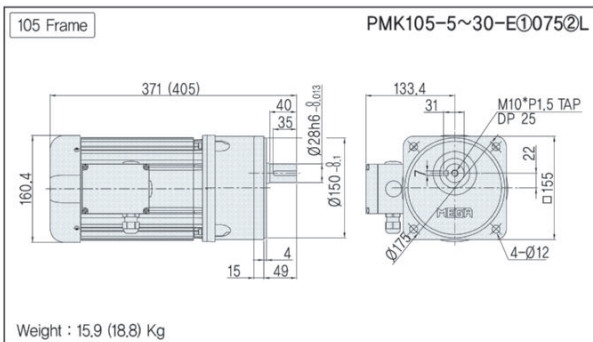

- Model type
- ① : Motor option (B, C, D)
- ② : Power (Voltage & Frequency)

※ Geared motors between 0.2~0.75kW, the size of the lead wire box and the terminal box is different.

Model Name Coding
 5Page

Specification for output shaft
 36Page

Technological Data
 37Page~

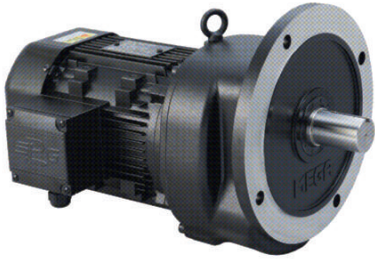

High Efficiency

PMK Series 3-Phase

1.5kW

■ SPECIFICATION

■ MOTOR

Output (kW)	Model Name	Poles	Voltage (V)	Freq. (Hz)	Rated Load			Duty	Degrees of protection	Insulation Classification	Protective Cooling System
					Current (A)	Speed (r/min)	Efficiency (%)				
1.5	PMK□-□-E□150R4□	4	220/380	60	6,30/3,60	1745	85,0	CONT.	IP55 (IP40)	F	Totally Enclosed Fan-Cooled
	PMK□-□-E□150W6□	4	200	50	6,70	1455	82,8				
			220	60	6,00	1750	85,0				
	PMK□-□-E□150X6□	4	380/400	50	3,55/3,50	1450/1455	82,8/82,8				
400/440			60	3,20/3,10	1745/1755	84,8/85,0					

Note) • The Brake Geared Motor is divided into 2 models : one is a non-water proof product with IP40 while the other is a waterproof product with IP55.

• The Models with IP40 and IP55 have the same electric characteristics.

■ GEARED MOTOR – 50Hz

Frame No.	135						153										
Reduction gear ratio	5	10	15	20	30	5	10	15	20	30	40	50	60	75	★90	★100	
Rotation speed (r/min)	300	150	100	75	50	300	150	100	75	50	37,5	30	25	20	16,6	15	
Allowable torque	kgf · m	4,6	9,3	13,9	18,5	27,8	4,6	9,3	13,9	18,5	27,8	35,8	44,8	53,8	67,2	73,9	73,9
	N · m	45	91	136	181	272	45	91	136	181	272	351	439	527	659	724	724
Allowable O.H.L	kgf	180	250	290	330	410	220	320	360	410	520	600	720	720	720	720	720
	N	1760	2450	2840	3230	4020	2160	3140	3530	4020	5100	5880	7060	7060	7060	7060	7060

Frame No.	172											
Reduction gear ratio	40	50	60	75	90	100	120	140	★150	★160	★180	★200
Rotation speed (r/min)	37,5	30	25	20	16,6	15	12,5	10,7	10	9,3	8,3	7,5
Allowable torque	kgf · m	35,8	44,8	53,8	67,2	80,6	89,6	108	125	125	125	125
	N · m	351	439	527	659	790	878	1060	1230	1230	1230	1230
Allowable O.H.L	kgf	600	720	720	720	720	1000	1000	1000	1000	1000	1000
	N	5880	7060	7060	7060	7060	9800	9800	9800	9800	9800	9800

■ GEARED MOTOR – 60Hz

Frame No.	135						153										
Reduction gear ratio	5	10	15	20	30	5	10	15	20	30	40	50	60	75	★90	★100	
Rotation speed (r/min)	360	180	120	90	60	360	180	120	90	60	45	36	30	24	20	18	
Allowable torque	kgf · m	3,9	7,7	11,6	15,4	23,1	3,9	7,7	11,6	15,4	23,1	29,9	37,3	44,8	56	61,5	61,5
	N · m	38	75	114	151	226	38	75	114	151	226	293	366	439	548	603	603
Allowable O.H.L	kgf	180	250	290	330	410	220	320	360	410	520	600	720	720	720	720	720
	N	1760	2450	2840	3230	4020	2160	3140	3530	4020	5100	5880	7060	7060	7060	7060	7060

Frame No.	172												
Reduction gear ratio	40	50	60	75	90	100	120	140	150	160	★180	★200	
Rotation speed (r/min)	45	36	30	24	20	18	15	12,8	12	11,2	10	9	
Allowable torque	kgf · m	29,9	37,3	44,8	56	67,1	74,7	89,6	105	112	119	125	125
	N · m	293	366	439	548	658	732	878	1025	1098	1170	1230	1230
Allowable O.H.L	kgf	600	720	720	720	720	1000	1000	1000	1000	1000	1000	
	N	5880	7060	7060	7060	7060	9800	9800	9800	9800	9800	9800	

Note) • Permissible O.H.L (allowable overhung load) is based on the central part of the outlet length for output shaft

• Permissible Torque is limited for the product with a mark "★" of reduction gear ratio

• Color indicates the same direction of motor rotation, while other color indicates the opposite direction of motor rotation.

Model Name Coding
▶ 5Page

Specification for output shaft
▶ 36Page

Technological Data
▶ 37Page~

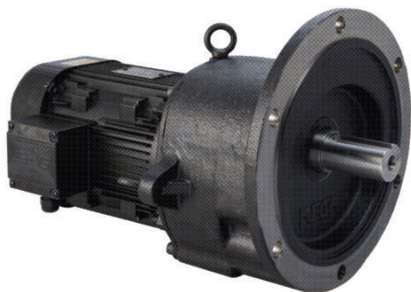

High Efficiency

PMK Series 3-Phase

2.2kW

■ SPECIFICATION

■ MOTOR

Output (kW)	Model Name	Poles	Voltage (V)	Freq. (Hz)	Rated Load			Duty	Degrees of protection	Insulation Classification	Protective Cooling System
					Current (A)	Speed (r/min)	Efficiency (%)				
2.2	PMK□-□-E□220R4□	4	220/380	60	7,80/4,50	1750	88,8	CONT.	IP55 (IP40)	F	Totally Enclosed Fan-Cooled
	PMK□-□-E□220W6□	4	200	50	8,70	1450	84,3				
			220	60	7,80	1750	88,8				
	PMK□-□-E□220X6□	4	380/400	50	4,55/4,50	1450/1455	84,3/84,3				
400/440			60	4,20/4,00	1735/1755	87,9/88,6					

Note) • The Brake Geared Motor is divided into 2 models : one is a non-water proof product with IP40 while the other is a waterproof product with IP55.

• The Models with IP40 and IP55 have the same electric characteristics.

■ GEARED MOTOR – 50Hz

Frame No.	153					172											
Reduction gear ratio	5	10	15	20	30	5	10	15	20	30	40	50	60	75	90	100	
Rotation speed (r/min)	300	150	100	75	50	300	150	100	75	50	37,5	30	25	20	16,6	15	
Allowable torque	kgf · m	6,8	13,6	20,4	27,1	40,7	6,8	13,6	20,4	27,1	40,7	52,6	65,7	78,9	98,6	118	125
	N · m	67	133	200	266	399	67	133	200	266	399	515	644	773	966	1159	1230
Allowable O.H.L	kgf	220	320	360	410	520	300	440	490	560	710	740	880	1000	1000	1000	1000
	N	2160	3140	3530	4020	5100	2940	4310	4800	5490	6960	7250	8620	9800	9800	9800	9800

Frame No.	181						
Reduction gear ratio	40	50	60	75	90	100	★120
Rotation speed (r/min)	37,5	30	25	20	16,6	15	12,5
Allowable torque	kgf · m	55,2	69	82,8	103,5	124,2	134,82
	N · m	541	677	812	1015	1218	1322
Allowable O.H.L	kgf	1230	1345	1410	1410	1410	1410
	N	12062	13190	13827	13827	13827	13827

■ GEARED MOTOR – 60Hz

Frame No.	153					172											
Reduction gear ratio	5	10	15	20	30	5	10	15	20	30	40	50	60	75	90	100	
Rotation speed (r/min)	360	180	120	90	60	360	180	120	90	60	45	36	30	24	20	18	
Allowable torque	kgf · m	5,7	11,3	17	22,6	33,9	5,7	11,3	17	22,6	33,9	43,8	54,8	65,7	82,2	98,6	110
	N · m	56	111	167	221	332	56	111	167	221	332	429	537	644	806	967	1080
Allowable O.H.L	kgf	220	320	360	410	520	300	440	490	560	710	740	880	1000	1000	1000	1000
	N	2160	3140	3530	4020	5100	2940	4310	4800	5490	6960	7250	8620	9800	9800	9800	9800

Frame No.	181						
Reduction gear ratio	40	50	60	75	90	100	★120
Rotation speed (r/min)	45	36	30	24	20	18	15
Allowable torque	kgf · m	45,6	21,6	68,4	85,5	102,6	114
	N · m	447	212	671	838	1006	1118
Allowable O.H.L	kgf	1230	1345	1410	1410	1410	1410
	N	12062	13190	13827	13827	13827	13827

Note) • Permissible O.H.L (allowable overhung load) is based on the central part of the outlet length for output shaft

• Permissible Torque is limited for the product with a mark "★" of reduction gear ratio

• ■ Color indicates the same direction of motor rotation, while other color indicates the opposite direction of motor rotation.

PMK TYPE DIMENSIONS [Lead wire Box Type & Terminal Box Type]

- Note) • Dimensions for IP40 model and IP55 model are the same.
 • The brake-attached model is applied to the Terminal Box Type for basic features, but does not apply to the lead box.

UNIT = mm

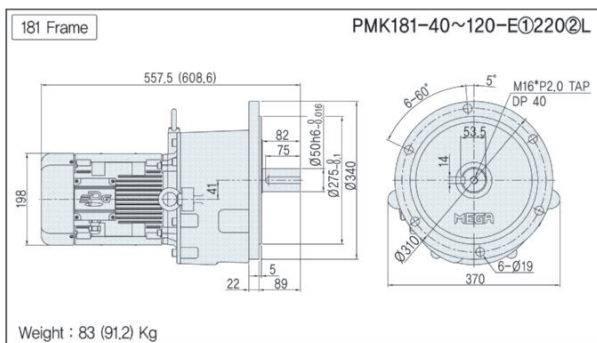
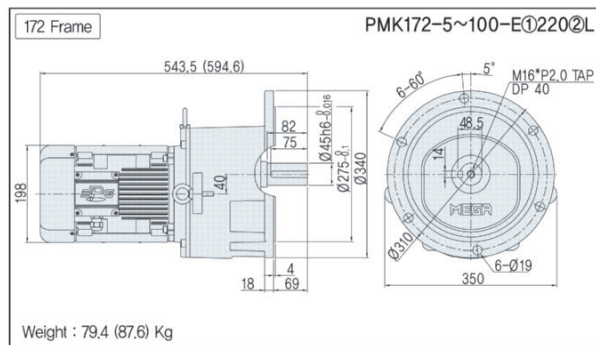
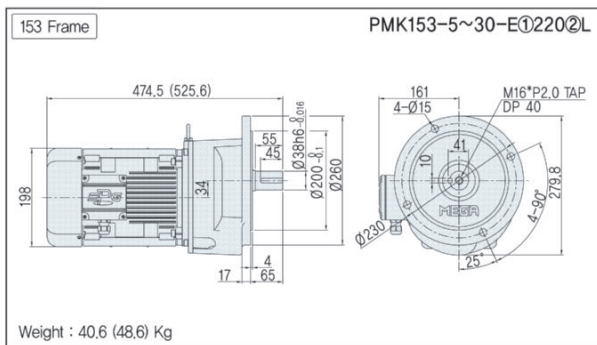

• Model type

- ① : Motor option (A, B, C, D)
- ② : Power (Voltage & Frequency)

■ Lead wire Box & Terminal Box

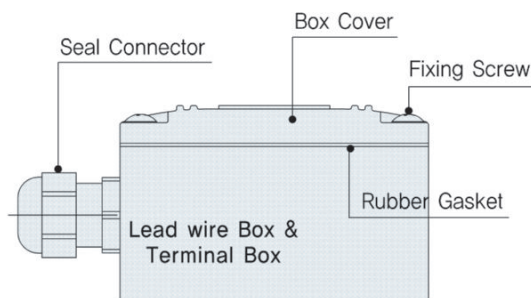

※ Geared motors between 1.5~3.7kW, the feature of the lead wire box and the terminal box is the same

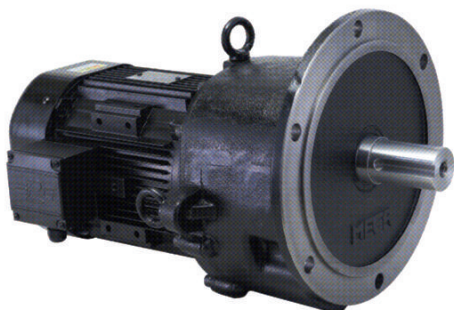

High Efficiency

PMK Series 3-Phase

3.7kW

■ SPECIFICATION

■ MOTOR

Output (kW)	Model Name	Poles	Voltage (V)	Freq. (Hz)	Rated Load			Duty	Degrees of protection	Insulation Classification	Protective Cooling System
					Current (A)	Speed (r/min)	Efficiency (%)				
3.7	PMK□-□-E□370R4□	4	220/380	60	14,50/8,35	1750	87,6	CONT.	IP55	F	Totally Enclosed Fan-Cooled

■ GEARED MOTOR – 50Hz

Frame No.	172					181											
Reduction gear ratio	5	10	15	20	30	5	10	15	20	30	40	50	60	75	90	100	
Rotation speed (r/min)	300	150	100	75	50	300	150	100	75	50	37,5	30	25	20	16,6	15	
Allowable torque	kgf · m	12	23,5	35	47	67	12	23,5	35	47	67	92,0	115,0	138,0	172,5	207,0	224,7
	N · m	118	230	343	461	657	118	230	343	461	657	902	1128	1353	1692	2030	2204
Allowable O.H.L	kgf	320	400	450	710	880	655	770	885	1000	1115	1230	1345	1410	1410	1410	1410
	N	3138	3923	4413	6963	8630	6423	7551	8679	9807	10934	12062	13190	13827	13827	13827	13827

■ GEARED MOTOR – 60Hz

Frame No.	172					181											
Reduction gear ratio	5	10	15	20	30	5	10	15	20	30	40	50	60	75	90	100	
Rotation speed (r/min)	360	180	120	90	60	360	180	120	90	60	45	36	30	24	20	18	
Allowable torque	kgf · m	9,6	19	28,8	38	56,5	9,6	19	28,8	38	56,5	76,0	95,0	114,0	142,5	171,0	190,0
	N · m	94	186	282	373	588	94	186	282	373	588	745	932	1118	1397	1677	1863
Allowable O.H.L	kgf	320	400	450	710	880	655	770	885	1000	1115	1230	1345	1410	1410	1410	1410
	N	3138	3923	4413	6963	8630	6423	7551	8679	9807	10934	12062	13190	13827	13827	13827	13827

- Note) • Permissible O.H.L (allowable overhung load) is based on the central part of the outlet length for output shaft
 • Permissible Torque is limited for the product with a mark "★" of reduction gear ratio
 • ■ Color indicates the same direction of motor rotation, while other color indicates the opposite direction of motor rotation.

Model Name Coding
 ▶ 5Page

Specification for output shaft
 ▶ 36Page

Technological Data
 ▶ 37Page~

PMK TYPE DIMENSIONS [Lead wire Box Type & Terminal Box Type]

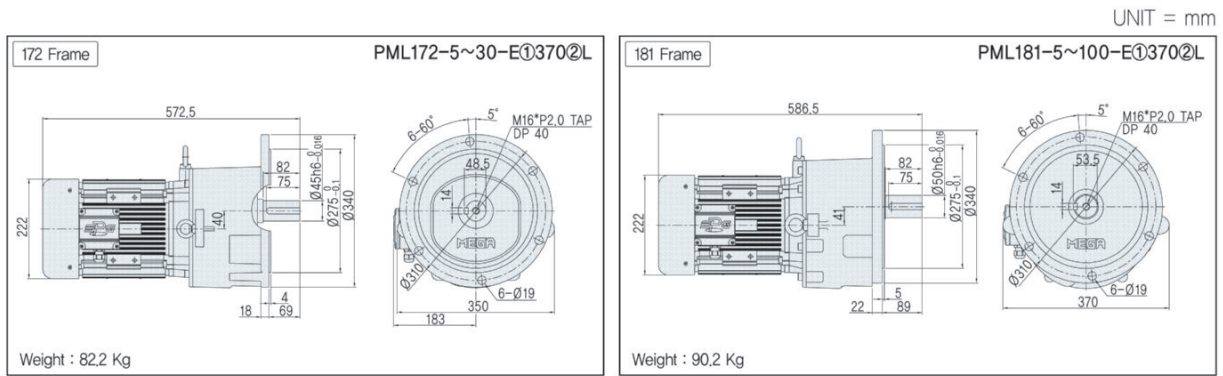

• **Model type**

- ① : Motor option (A, B)
- ② : Power (Voltage & Frequency)

■ **Lead wire Box & Terminal Box**

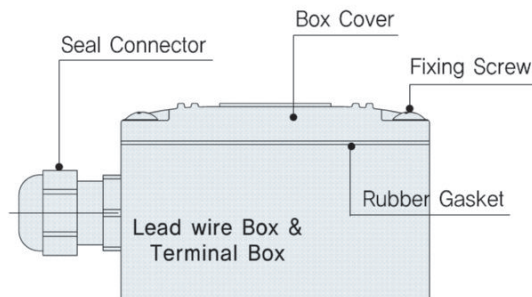

※ Geared motors between 1.5~3.7kW, the feature of the lead wire box and the terminal box is the same